

Rev. 1.1 – Mai 2003
Devices: eWON4000

Overview

This document defines a checklist for physically installing a Modbus network.

Network installation

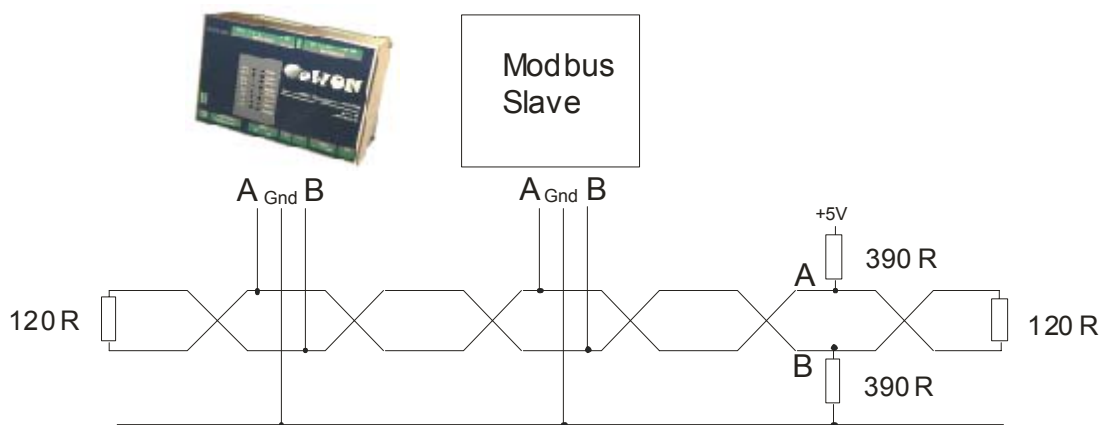

- **Cable:** The cable used for connecting modbus device must be **twisted pair** with a **120 Ohm matching impedance**. An additional 3rd wire is used for connecting signal ground between equipments.
- **Terminating resistors:** At each extremity of the bus, a 120 Ohm resistor must be installed between the A and B line. This is required for loading the bus and avoiding reflections.
- **Bias resistors:** The bus must be held in fail safe condition when no data are transferred. This is done by adding a 390 Ohm resistor between Gnd and B and another 390 Ohm resistor between A and +5V

Checklist

Do the following tests:

	Value expected	Check
Power off system		
At first side of the bus: Measure resistor between A and B	50 to 75 Ohm	
At first side of the bus: Measure resistor between Gnd and B	350 to 430 Ohm	
Other side of the bus: Measure resistor between A and B	50 to 75 Ohm	
Other side of the bus: Measure resistor between Gnd and B	350 to 430 Ohm	
Disconnect eWON from the bus, Power on system		
Measure voltage between B and A (B is reference of measure)	0.300 to 0.450V	
Measure voltage between Gnd and B	+/- 2V	
Connect eWON to the bus, Power on system		
Check RS485 LED status: must be off , except during responses from the slaves on the bus (depends on polling frequency). If A and B have been inverted, you will probably see the led solid green.	LED OFF	

All (7) tests must be passed, if not, you need to recheck your network physical installation.